



**Faculty of Engineering and Technology  
Electrical and Computer Engineering  
Department**

**ENEE2102  
CIRCUITS LAB**

**Student's name: Anas Abdelhalim Tomaizeh**

**Student's number: 1152325**

**Experiment #6**

**Pre lab**

**8/11/2017**

**Eng: Qais samara**

**DR: Hakam shhada**

Q2)

Circuit diagram:

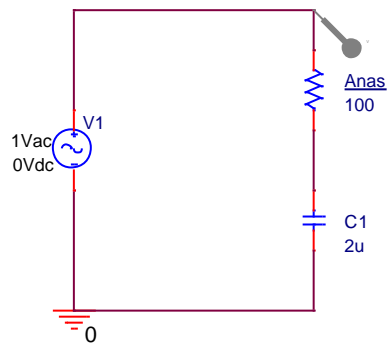

The result:

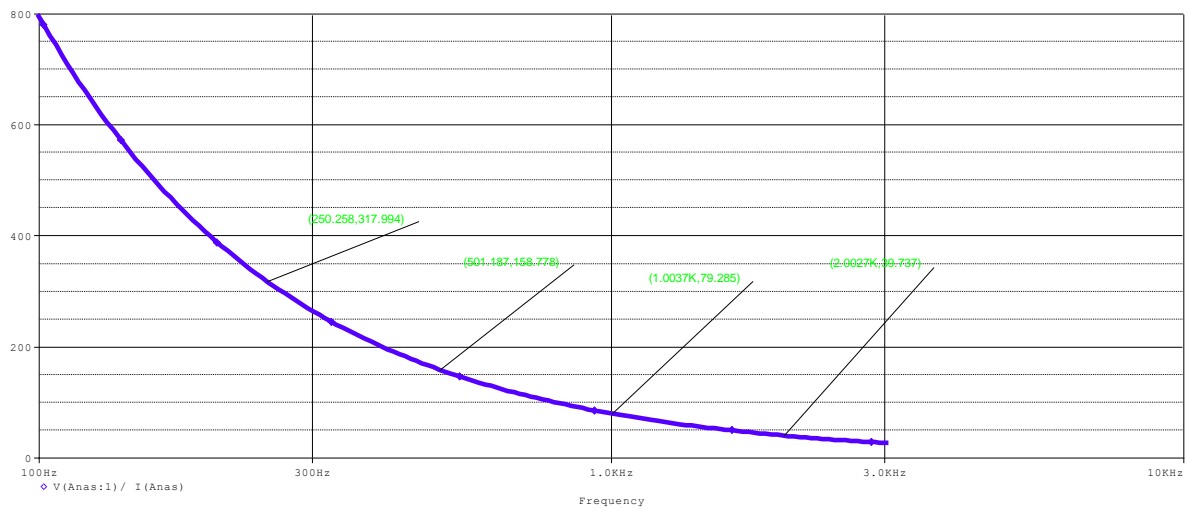

Q3)

For R=1K : circuit diagram:

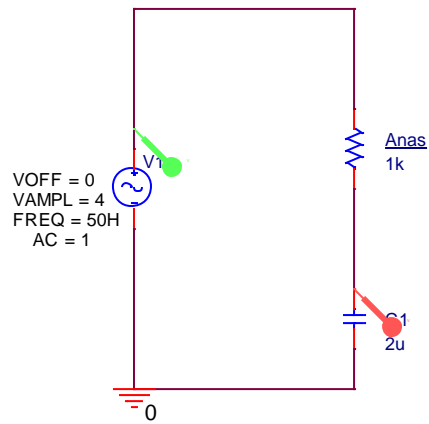

The result:

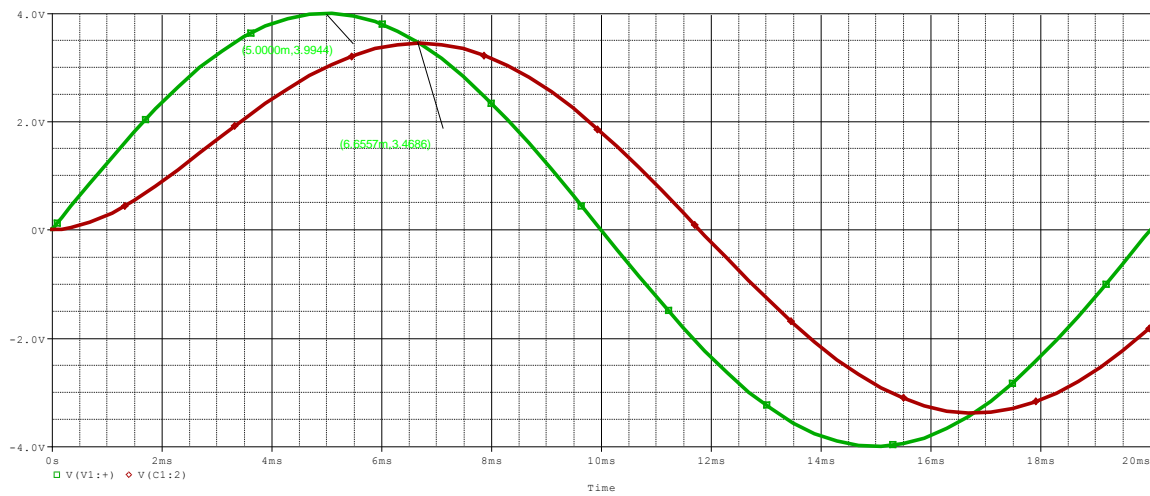

$$\Delta\theta = 360 * 50 * (6.65 - 5.0) \text{m} = 29.7$$

For R=10K: the circuit diagram:

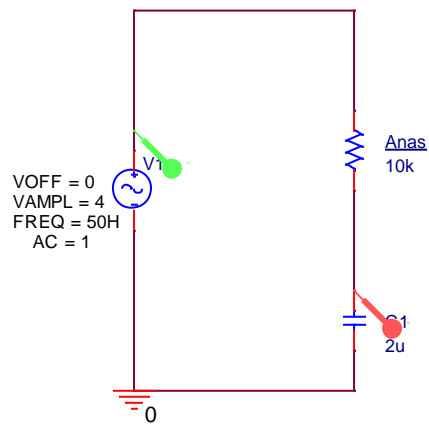

The result:

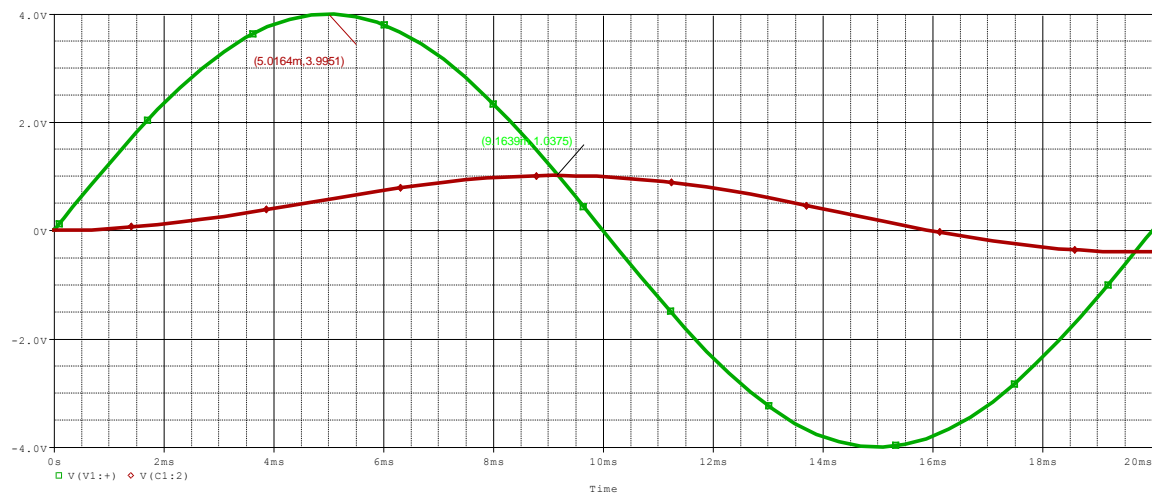

$$\Delta\theta = 360 * 50 * (9.1 - 5.0927) \text{m} =$$

For R=5k: circuit diagram:

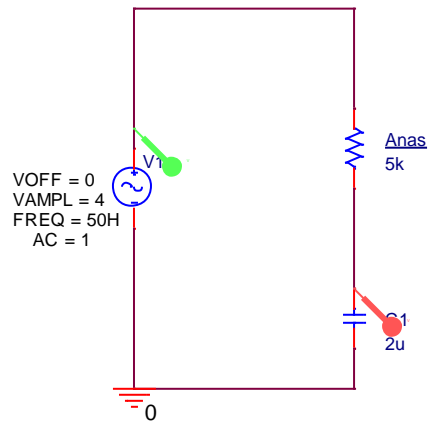

The result:

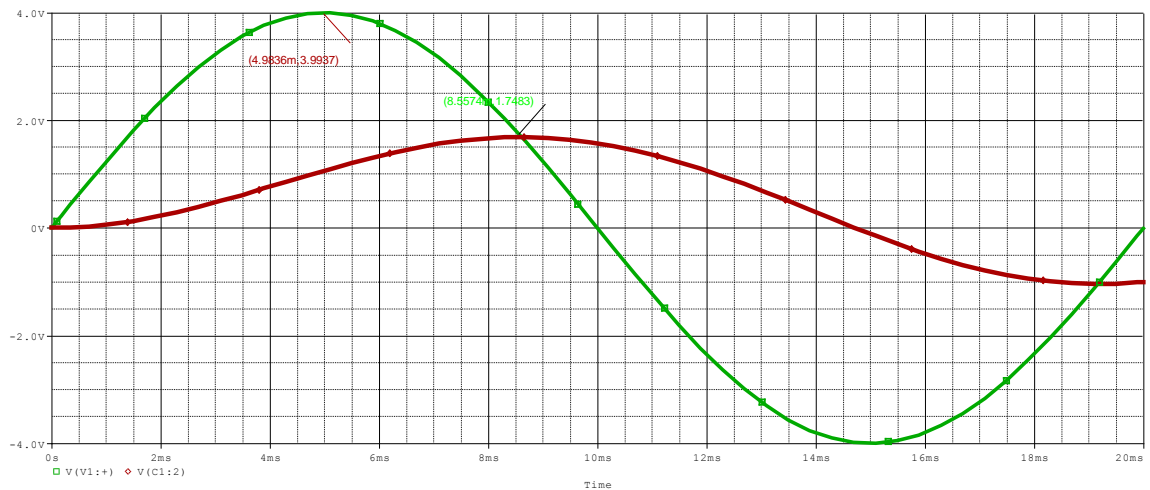

$$\Delta\theta = 360 * 50 * (8.5 - 4.98) \text{m} =$$

Q4)

For R=1K the circuit diagram:

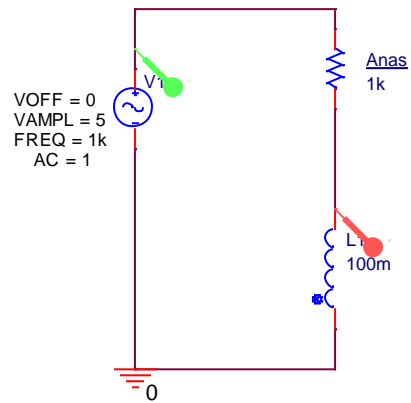

The result:

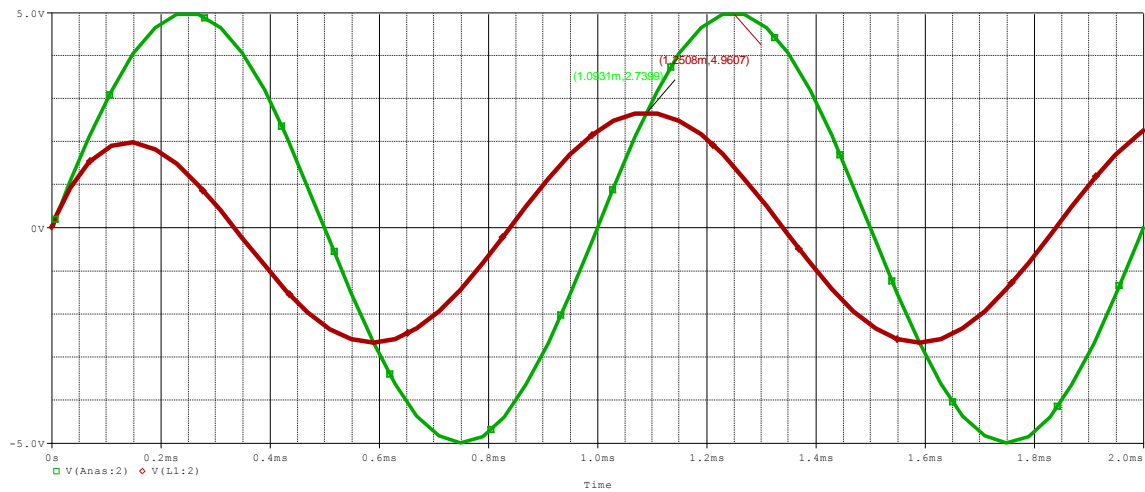

$$\Delta\theta = 360 \cdot 50 \cdot (1.25 - 1.09) \text{m} =$$

For R=5K:

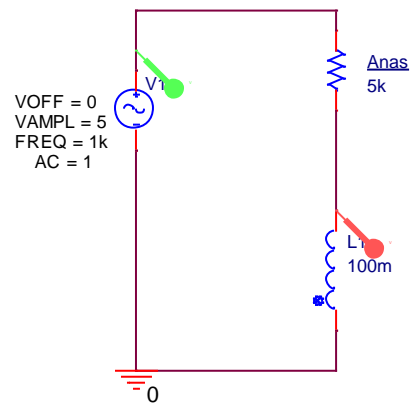

The result:

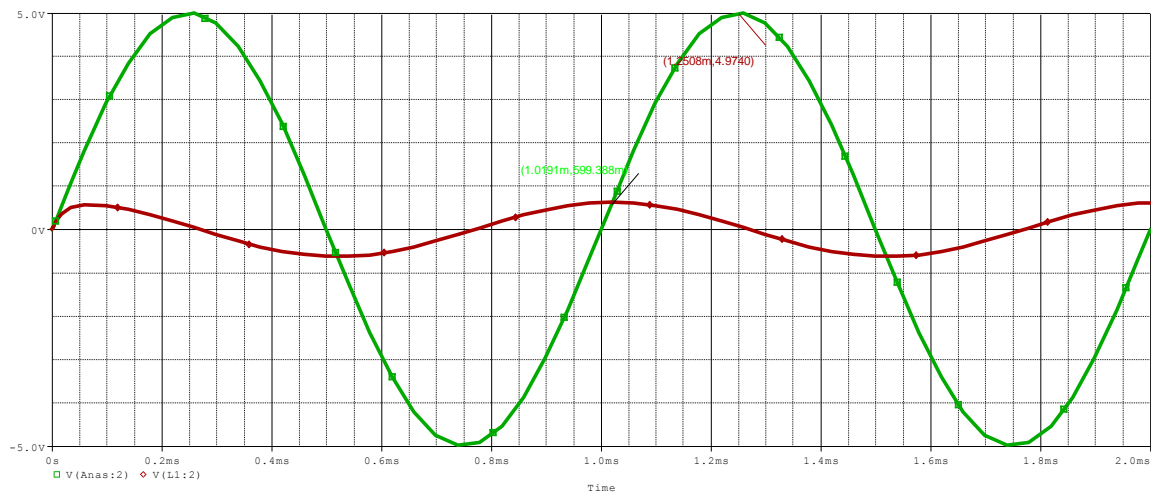

$$\Delta\theta = 360 * 50 * (1.250 - 1.019) \text{m} =$$

For R= 10K:

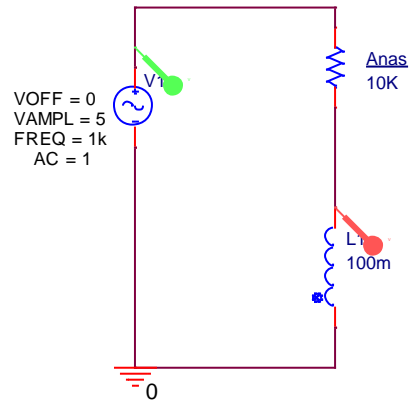

The result:

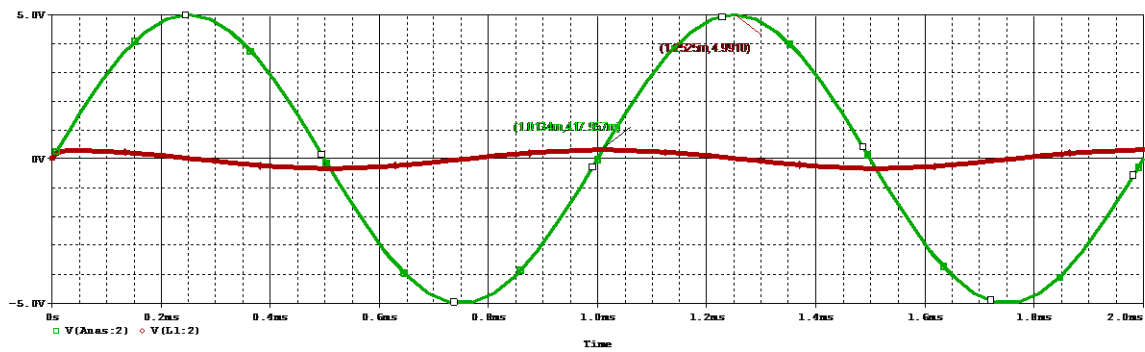

$$\Delta\theta = 360 * 50 * (1.252 - 1.0134) \text{ms} =$$